

Ranchu (Ornamental Goldfish)

© Ronald Koh - 1994

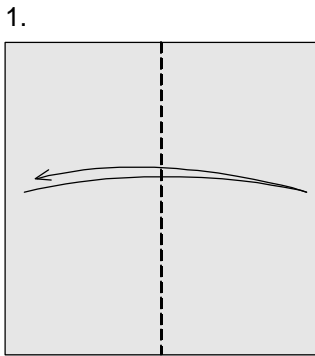

1. A 12 to 15 cm square of paper will do nicely. Fold in half and unfold.

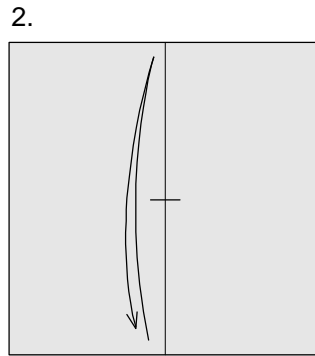

2. Fold and unfold vertically, creasing the centre only.

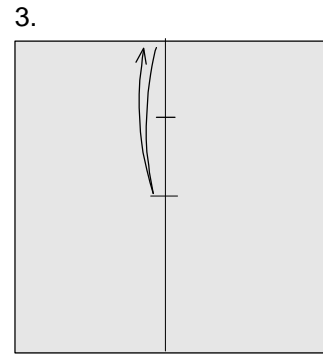

3. Fold to the mark made in step 2 and unfold, creasing in the centre only.

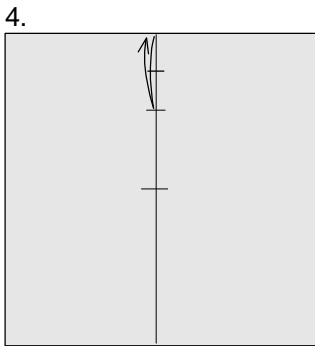

4. Fold and unfold again as shown. This marks an eighth of the height.

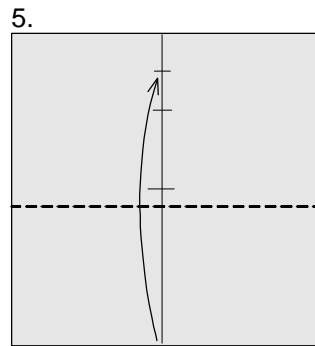

5. Bring the bottom edge of the paper to the crease made in step 4 ...

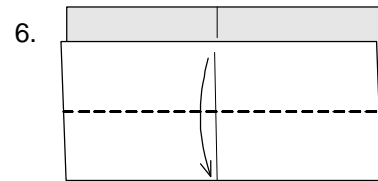

6. ... then fold down again.

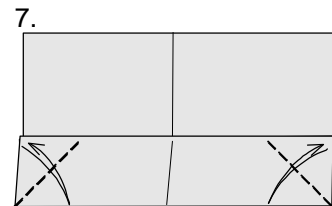

7. Fold and unfold each corner, creasing well.

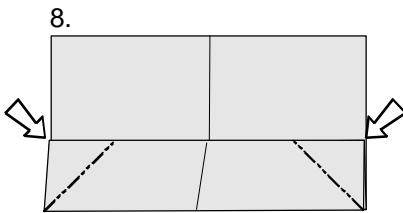

8. Inside reverse fold along creases made in step 7.

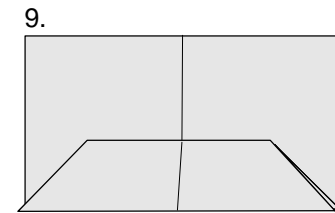

9. Turn paper over.

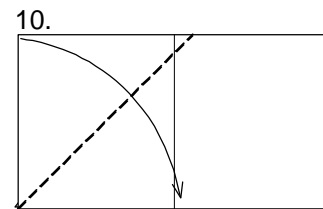

10. Fold down ...

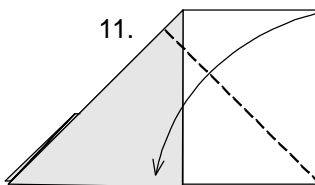

11. ... and again on the right.

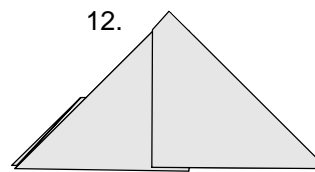

12. Turn over again

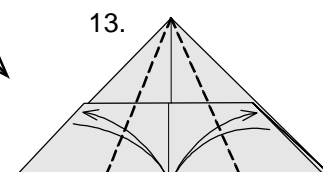

13. Fold the diagonal edges of the paper to the line in the middle, crease firmly, and unfold.

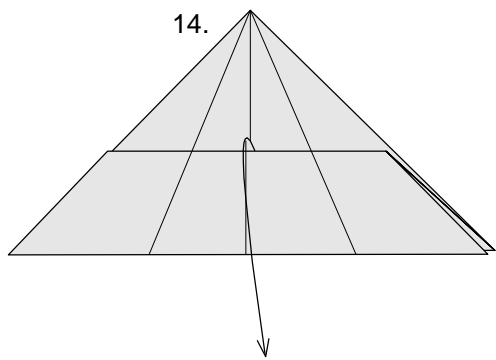

14. Bring down this layer ...

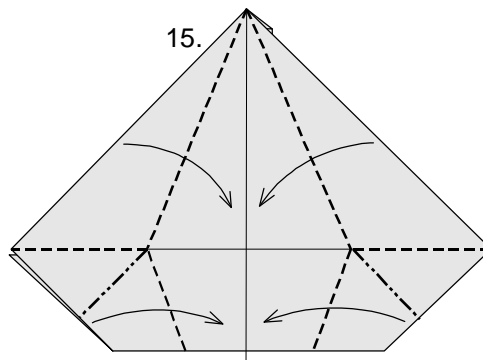

15. ... like this, then rabbit, ear both sides along creases made previously.

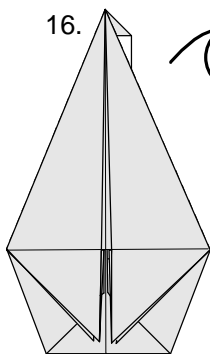

16. Turn over.

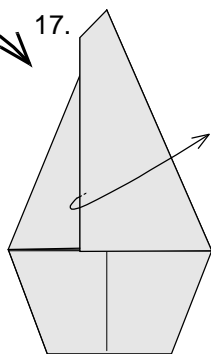

17. Open out this layer to the right.

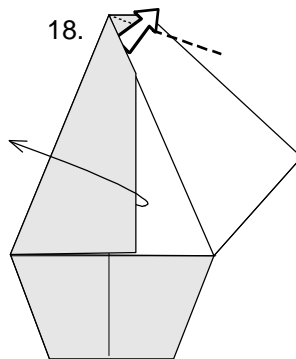

18. Lift out the hidden paper at the top, then open out the layer on the left.

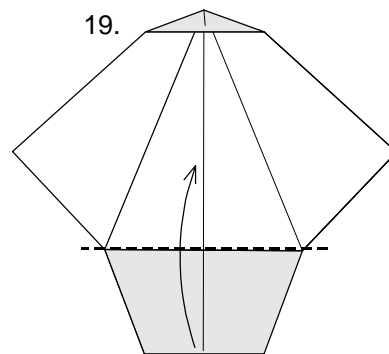

19. Fold up the lower portion of the assembly as shown.

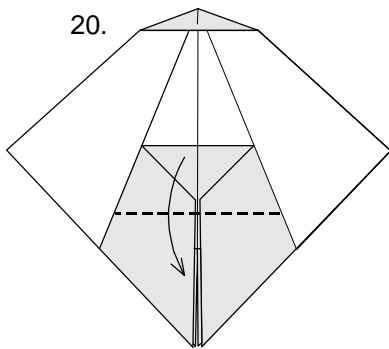

20. Valley fold ...

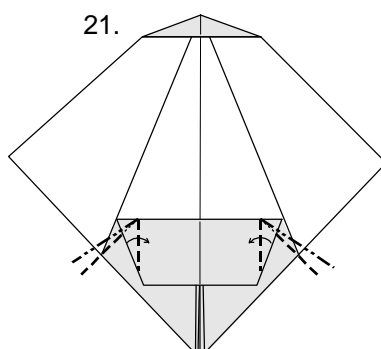

21. ... then crimp fold each side.

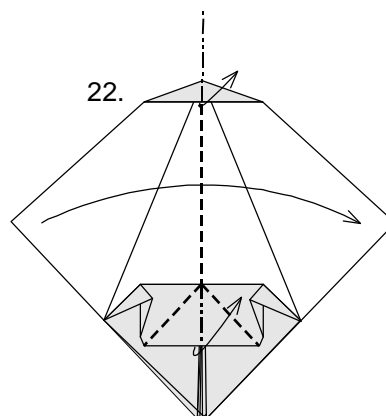

22. Fold assembly in half while lifting out the layer at the top and a triangle at the bottom ...

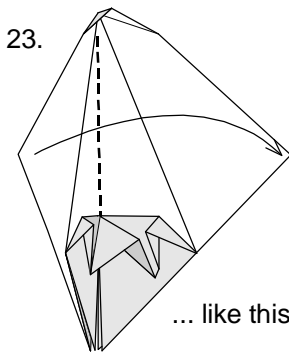

23. ... like this ...

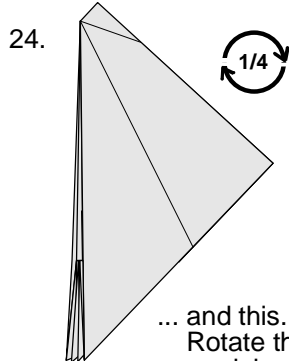

24. ... and this. Rotate the model

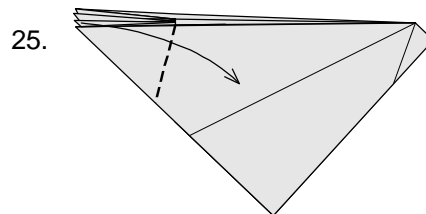

25. Fold the first two flaps to the right, and crease firmly.

26.

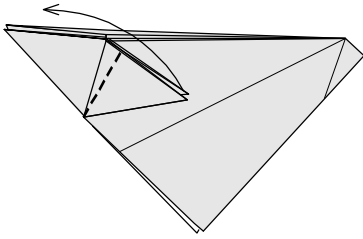

Now valley fold ...

27.

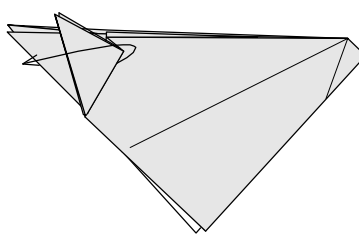

... then unfold Steps 25 and 26.

28.

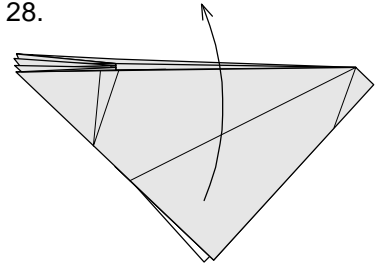

Lift up the first layer ...

29.

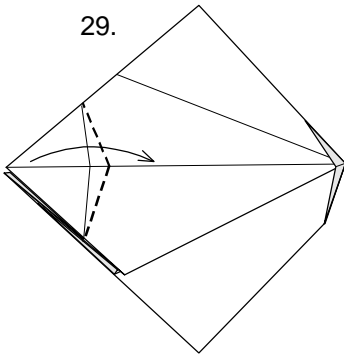

... then fold in the left corner along creases made in Step 26.

30.

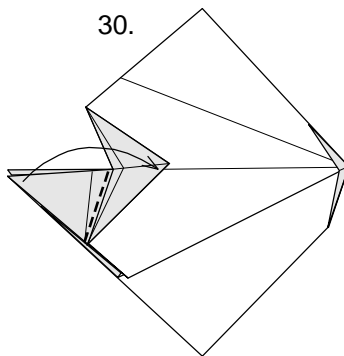

Fold the next layer on the left to the right as illustrated ...

31.

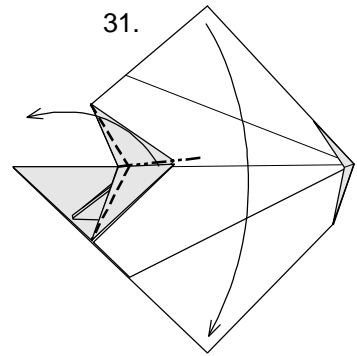

... then bring down the top flap as you valley fold the assembly on the left along creases made in Step 25 ...

32.

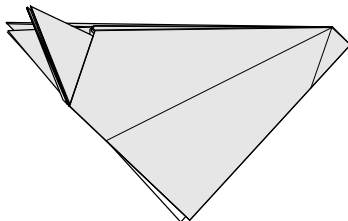

... like this. Repeat Steps 25 to 31 on the other side.

33.

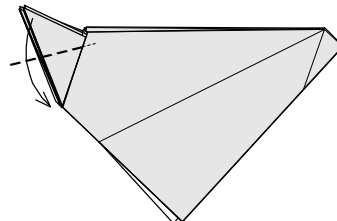

Fold down the first layer ...

34.

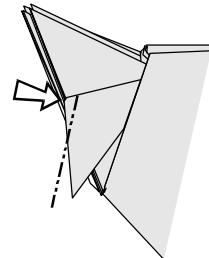

... then reverse fold the resulting corner as shown.

35.

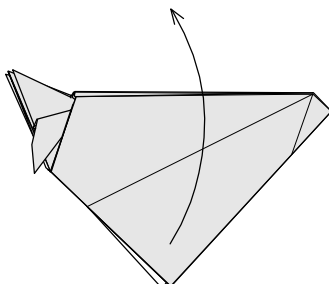

Bring up the top layer again ...

36.

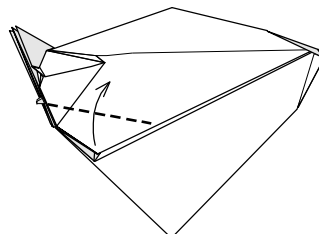

... then valley fold the next layer ...

37.

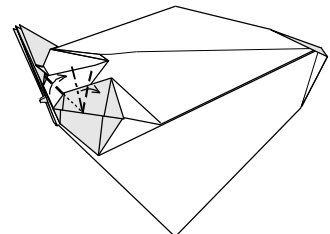

... and then valley fold again and crimp as illustrated.

38.

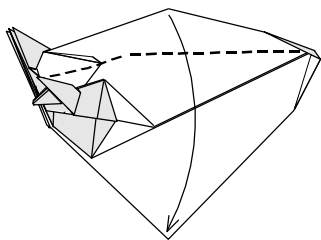

Now bring down the layer at the top again and repeat Steps (?) to 37 on the other side.

39.

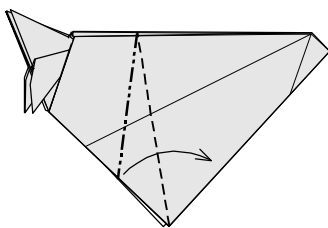

Crimp fold according to diagrammed proportions, crease firmly ...

40.

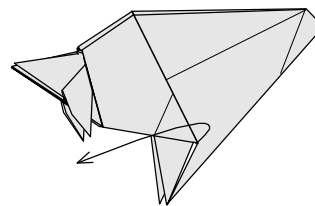

... and unfold.

41.

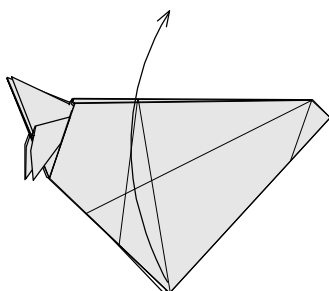

Bring up the top layer again.

42.

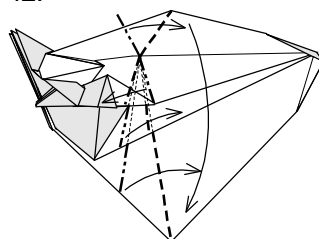

Crimp fold each of the four layers separately as shown, then close the assembly by bring the top layer down again.

43.

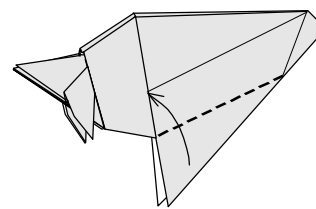

Fold up as shown ...

44.

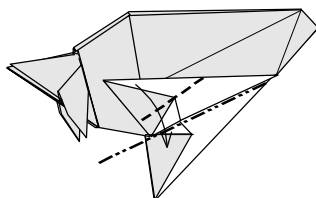

... then down again. Repeat at the back from here through Step 47 ...

45.

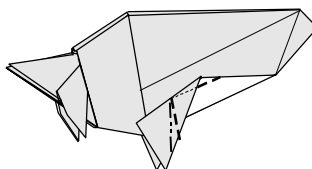

... then crimp fold as illustrated.

46.

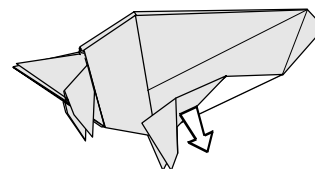

Now open out to unfold Steps 43 to 45.

47.

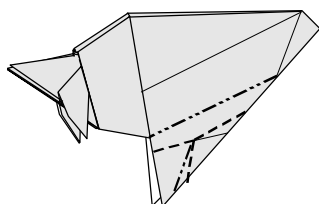

Collapse the assembly under the body as shown, using crease lines made previously.

48.

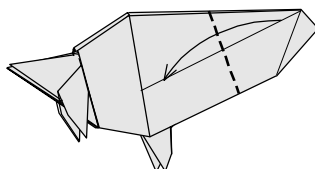

Your model should now look like this. Valley fold, creasing firmly ...

49.

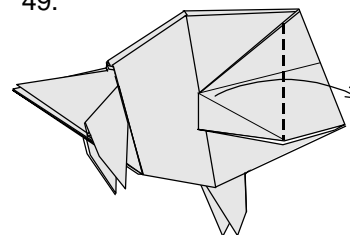

... and yet again. The illustration is slightly enlarged from here on.

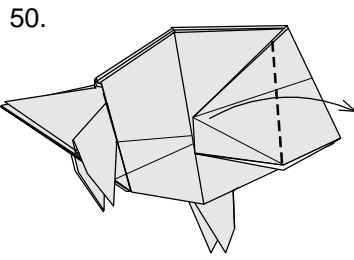

... and yet again.

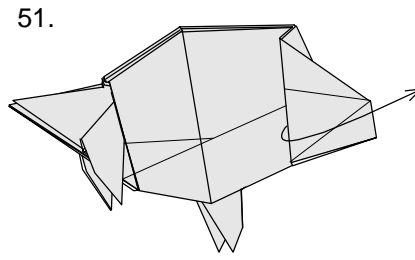

Now unfold Steps 49 and 50.

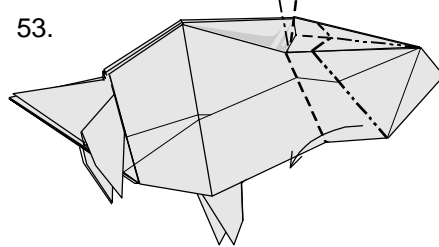
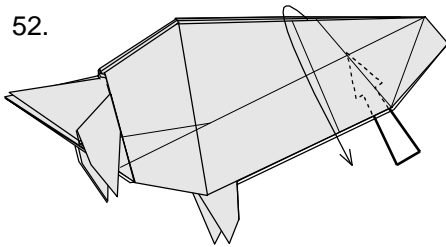

Hidden between the external body layers are two narrower pleated layers. Push up from the bottom to open out the pleat of the hidden layer nearest to you, while simultaneously separating the first and second layers at the top ...

... like this.
Now crimp fold both sides of the head along creases made previously while bringing out the top of the head ...

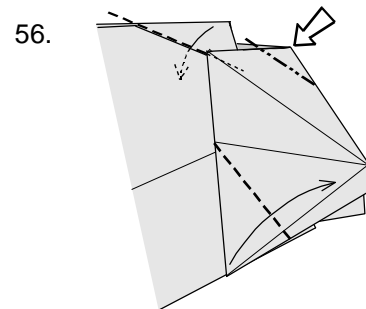
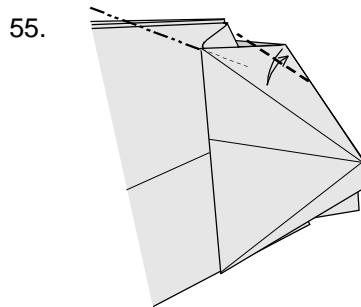
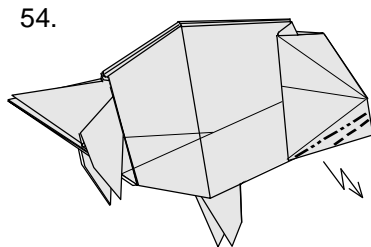

Crimp fold both sides of the model to form the mouth.

Fold and unfold at the top of the head, creasing firmly. Mountain fold at the base of the neck.

Now sink at the top of the head, then continue folding as illustrated.

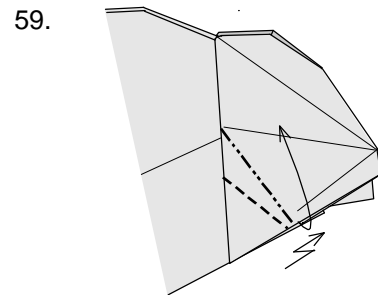
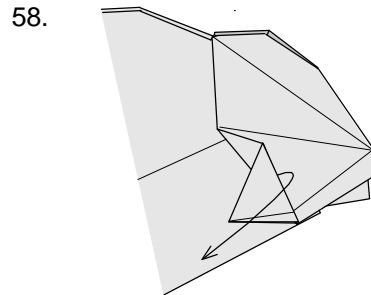
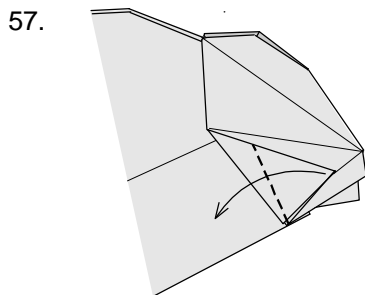

Valley fold to the left again then unfold Steps 56 and 57.

Separate the two layers of this flap and crimp fold along creases made previously.

60.

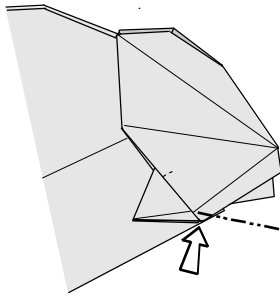

Sink the little corner at the bottom.
Diagrams 61 and 62 shows a close up of this part of the model.

61.

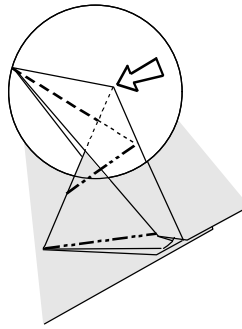

Mountain fold twice as illustrated.
The upper fold should automatically form a hidden gusset.

62.

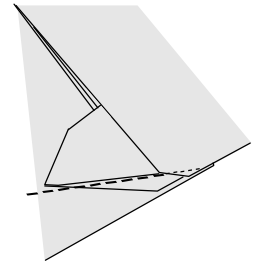

Valley fold the next layer.

63.

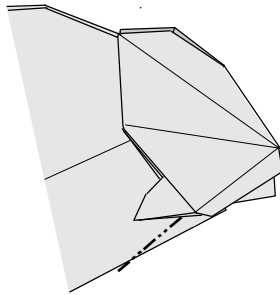

Mountain fold under and repeat from Step 56 on the other side of the head.

64.

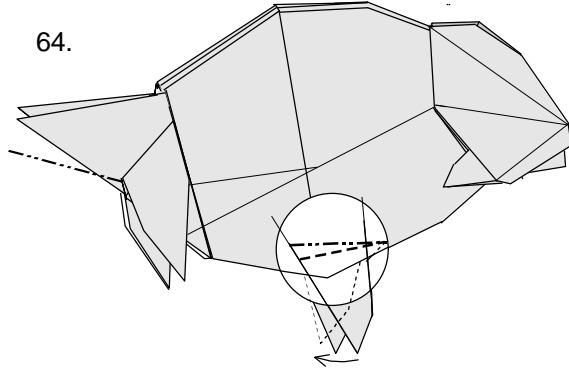

Crimp fold each of the two fins to bring them a little further to the back.
Shape the central area of each side of the tail as illustrated.

65.

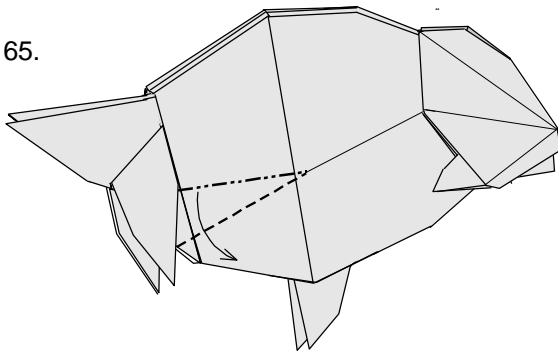

Finally, crimp fold both sides of the body along creases made previously, making sure that the body convexes outwards.

